

Installation Note

IF Access Upgrade Kit

For PNA Series Microwave Network Analyzers

Network Analyzer Model Number	Upgrade Kit Part Number
E8361A, E8362B, E8363B, E8364B	E8362-60116



Agilent Part Number: E8362-90115

Printed in USA July 2007

Supersedes all previous printings.

© Agilent Technologies, Inc. 2004, 2005, 2007

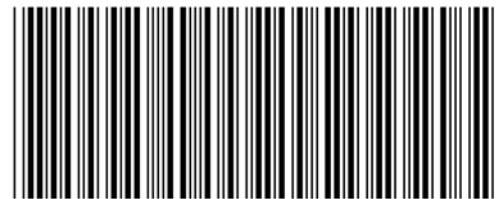

E8362-90115

WARRANTY STATEMENT

THE MATERIAL CONTAINED IN THIS DOCUMENT IS PROVIDED “AS IS,” AND IS SUBJECT TO BEING CHANGED, WITHOUT NOTICE, IN FUTURE EDITIONS. FURTHER, TO THE MAXIMUM EXTENT PERMITTED BY APPLICABLE LAW, AGILENT DISCLAIMS ALL WARRANTIES, EITHER EXPRESS OR IMPLIED WITH REGARD TO THIS MANUAL AND ANY INFORMATION CONTAINED HEREIN, INCLUDING BUT NOT LIMITED TO THE IMPLIED WARRANTIES OF MERCHANTABILITY AND FITNESS FOR A PARTICULAR PURPOSE. AGILENT SHALL NOT BE LIABLE FOR ERRORS OR FOR INCIDENTAL OR CONSEQUENTIAL DAMAGES IN CONNECTION WITH THE FURNISHING, USE, OR PERFORMANCE OF THIS DOCUMENT OR ANY INFORMATION CONTAINED HEREIN. SHOULD AGILENT AND THE USER HAVE A SEPARATE WRITTEN AGREEMENT WITH WARRANTY TERMS COVERING THE MATERIAL IN THIS DOCUMENT THAT CONFLICT WITH THESE TERMS, THE WARRANTY TERMS IN THE SEPARATE AGREEMENT WILL CONTROL.

DFARS/Restricted Rights Notice

If software is for use in the performance of a U.S. Government prime contract or subcontract, Software is delivered and licensed as “Commercial computer software” as defined in DFAR 252.227-7014 (June 1995), or as a “commercial item” as defined in FAR 2.101(a) or as “Restricted computer software” as defined in FAR 52.227-19 (June 1987) or any equivalent agency regulation or contract clause. Use, duplication or disclosure of Software is subject to Agilent Technologies’ standard commercial license terms, and non-DOD Departments and Agencies of the U.S. Government will receive no greater than Restricted Rights as defined in FAR 52.227-19(c)(1-2) (June 1987). U.S. Government users will receive no greater than Limited Rights as defined in FAR 52.227-14 (June 1987) or DFAR 252.227-7015 (b)(2) (November 1995), as applicable in any technical data.

Safety Notes

The following safety notes are used throughout this document. Familiarize yourself with each of these notes and its meaning before performing any of the procedures in this document.

WARNING	Warning denotes a hazard. It calls attention to a procedure which, if not correctly performed or adhered to, could result in injury or loss of life. Do not proceed beyond a warning note until the indicated conditions are fully understood and met.
----------------	---

CAUTION	Caution denotes a hazard. It calls attention to a procedure that, if not correctly performed or adhered to, could result in damage to or destruction of the instrument. Do not proceed beyond a caution sign until the indicated conditions are fully understood and met.
----------------	---

Description of the IF Access Upgrade, Option H11

This upgrade adds additional hardware to your PNA that allows for external connection to the internal IF path of the PNA.

About Installing the Upgrade Kit

IMPORTANT Option H11, IF Access, can only be installed on analyzers with the option combinations listed below as “Products affected”. If your analyzer does not have the proper options (as listed below), it will be necessary to install those options **BEFORE** installing this option (Option H11).

Products affected.	E8361A, E8362B, E8363B, E8364B with Options UNL, 014, 080, and 081 (with or without Option 016)
Installation to be performed by	Agilent service center
Estimated time to install the hardware.	120 minutes
Estimated time to test the upgraded analyzer	60 minutes

If you need assistance, refer to [“Getting Assistance from Agilent” on page 28](#).

Items Included in the Upgrade Kit

Check the contents of your kit against the following list. If any item is missing or damaged, contact Agilent Technologies. Refer to [“Getting Assistance from Agilent” on page 28](#).

Table 1 Option H11 Upgrade Kit (E8362-60116)

Ref. Desig.	Model Number	Description	Qty	Part Number
Parts for ALL affected analyzers (See page 3.)				
	All	Installation note (this document)	1	E8362-90115
A47	All	Coupler, RF path	2	0955-0148
A48		Coupler, LO path		
	All	Bracket, LO coupler	1	E8361-00005
	All	Machine screw, M3.0 x 6 (to attach LO coupler bracket)	2	0515-0430
	All	Machine screw, M2.0 x 6 (to attach couplers)	4	0515-0658
	All	Drill, 3.2 mm (1/8-in) (for RF coupler mounting holes)	1	N/A
	All	Rear panel (for A16 test set motherboard)	1	E8361-00006
W101 - W108	All	RF cable, flexible (8.33 MHz IF IN and PULSE IN cables)	8	8120-5401
	All	Lock washer (for cables W101 - W108)	8	2190-0102
	All	Hex nut (for cables (W101 - W108)	8	2950-0035
	All	SMA connector, f-f (TEST SET DRIVERS connectors)	2	1250-1251
	All	SMA coaxial terminations, 50 ohm (for TEST SET DRIVERS connectors)	2	1810-0118
A49	All	IF multiplexer board	1	E8361-60043
W109	All	RF cable, semi-rigid, A12 source to A47 RF coupler	1	E8361-20050
W113	All	RF cable, semi-rigid, A47 RF coupler to rear panel TEST SET DRIVERS RF connector	1	E8361-20052
W110	All	RF cable, semi-rigid, A18 MA 24 to A48 LO coupler	1	E8361-20053
W114	All	RF cable, semi-rigid, A48 LO coupler to rear panel TEST SET DRIVERS LO connector	1	E8361-20054
W112	All	RF cable, semi-rigid, A48 LO coupler to A19 splitter	1	E8361-20055
W15	E8362/3/4B	RF cable, semi-rigid, A19 splitter to A20 LODA	1	E8361-20056
W16	E8361A			
W16	E8362/3/4B	RF cable, semi-rigid, A19 splitter to A20 LODA	1	E8361-20057
W17	E8361A			
W111	E8362B	RF cable, semi-rigid, A47 RF coupler to A22 switch	1	E8362-20055
	E8361A, E8363/4B	RF cable, semi-rigid, A47 RF coupler to A21 SOMA 50		E8361-20051
Parts for E8361A ONLY				
W98	E8361A	RF cable, semi-rigid, RCVR R1 IN to A45 switch	1	E8361-20058

Installation Procedure for the Upgrade Kit

The network analyzer must be in proper working condition prior to installing this option. Any necessary repairs must be made before proceeding with this installation.

WARNING **This installation requires the removal of the analyzer's protective outer covers. The analyzer must be powered down and disconnected from the mains supply before performing this procedure.**

Electrostatic Discharge Protection

Protection against electrostatic discharge (ESD) is essential while removing assemblies from or connecting cables to the network analyzer. Static electricity can build up on your body and can easily damage sensitive internal circuit elements when discharged. Static discharges too small to be felt can cause permanent damage. To prevent damage to the instrument:

- *always* have a grounded, conductive table mat in front of your test equipment.
- *always* wear a grounded wrist strap, connected to a grounded conductive table mat, having a 1 M Ω resistor in series with it, when handling components and assemblies or when making connections.
- *always* wear a heel strap when working in an area with a conductive floor. If you are uncertain about the conductivity of your floor, wear a heel strap.
- *always* ground yourself before you clean, inspect, or make a connection to a static-sensitive device or test port. You can, for example, grasp the grounded outer shell of the test port or cable connector briefly.

Figure 1 shows a typical ESD protection setup using a grounded mat and wrist strap. Refer to “Tools and Equipment Required for the Installation” on page 7 for part numbers.

Figure 1 **ESD Protection Setup**

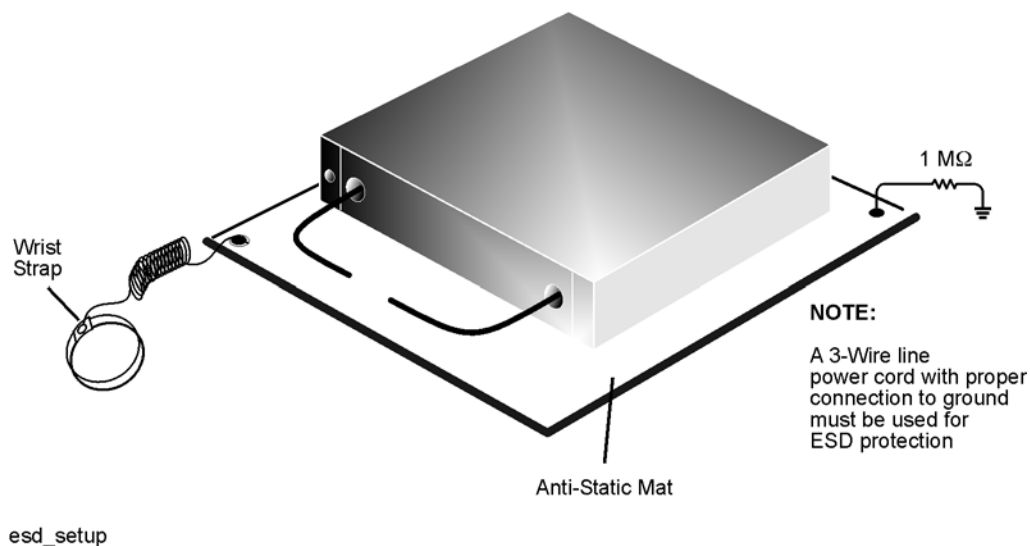

Overview of the Installation Procedure

NOTE Although this procedure applies to the E8361A, E8362B, E8363B, and E8364B, only the E8364B is shown in most of the illustrations. The other analyzer models are similar in appearance and procedural differences are noted where appropriate

- Step 1. Remove the Outer Cover
- Step 2. Raise and Remove the Receiver Swing Deck
- Step 3. Remove the A41 Hard Disk Drive Assembly (HDDA) and Shield
- Step 4. Remove the A21 SOMA 50 and Port 2 Assemblies
- Step 5. Remove the A18 MA 24 and the A19 Splitter
- Step 6. Remove the A16 Test Set Motherboard
- Step 7. Replace the Rear-Panel Assembly
- Step 8. Drill A47 RF Coupler Mounting Holes
- Step 9. Install the New A16 Test Set Motherboard
- Step 10. Reinstall the A41 Hard Disk Drive Assembly (HDDA) and Shield
- Step 11. Reinstall the A21 SOMA 50 and the Port 2 Assemblies
- Step 12. Install the A47 RF Coupler
- Step 14. Install the A18 MA 24, A19 Splitter, and A48 LO Coupler
- Step 15. Install the A49 IF Multiplexer Board
- Step 16. Reinstall the Receiver Swing Deck and Associated Cables
- Step 17. Reinstall the Outer Cover
- Step 18. Enable Option H11
- Step 19. Verify the Functionality of Option H11

Tools and Equipment Required for the Installation

Description	Agilent Part Number
Tools	
5/16-inch torque wrench (set to 10 in-lbs)	N/A
T-6 TORX driver (set to 7 in-lbs)	N/A
T-10 TORX driver (set to 9 in-lbs)	N/A
T-20 TORX driver (set to 21 in-lbs)	N/A
Power hand drill with 3.2 mm (1/8-in) drill bit	N/A
ESD Equipment	
ESD grounding wrist strap	9300-1367
5 ft grounding cord for wrist strap	9300-0980
2 x 4 ft conductive table mat and 15 ft grounding wire	9300-0797
ESD heel strap (for use with conductive floors)	9300-1308

Test Equipment Required for Post-Installation Calibration Adjustments

Description	Models Used With	Agilent Part Number
Power meter	All	E4418B/E4419B
Power sensor, Type-N (100 kHz–4.2 GHz)	All	8482A
Power sensor, 3.5 mm (4.2 GHz–20 GHz)	E8362B	E4413A or 8485A
Power sensor, 2.4 mm (4.2 GHz–50 GHz)	E8361A, E8363B, E8364B	8487A
Power sensor, V-Band (50 GHz–67 GHz) ^a	E8361A	V8486A
Adapter, WR-15 to 1.85 mm (m) ^a	E8361A	V281B
Adapter, 1.85 mm (f) to 1.85 mm (f) ^b	E8361A	85058-60114
Adapter, 2.4 mm (f) to 2.4 mm (f) ^b	E8363B, E8364B	11900B
Adapter, Type-N (f) to 2.4 mm (f)	E8361A, E8363B, E8364B	11903B
Test cable, 3.5 mm (f) to 3.5 mm (f)	E8362B	85131C/85131E
Test cable, 2.4 mm (f) to 2.4 mm (f) ^b or Test cable, 1.85 mm (f) to 1.85 mm (f) ^b	E8363B, E8364B	85133C/85133E
	E8361A	N4697E
Pulse Generator	All	8110A or 81110A
Function Generator	All	33120A
Test Set I/O Tester	All	E8361-60063
10-dB pad and BNC adapters	All	8493B
GPIB and BNC cables	All	10833A

- a. This sensor and adapter must be calibrated together by the Agilent factory. The data supplied are only valid as long as the sensor and adapter remain connected.
- b. The 1.85 mm connector has the same ruggedness and is compatible with the 2.4 mm connector. 1.85 mm and 2.4 mm connectors and adapters may be used interchangeably.

Step 1. Remove the Outer Cover

Refer to [Figure 2](#) for this procedure.

CAUTION This procedure is best performed with the analyzer resting on its front handles in the vertical position. *Do not place the analyzer on its front panel without the handles.* This will damage the front panel assemblies.

1. Disconnect the power cord (if it has not already been disconnected).
2. Remove the strap handles (item ⑤) by loosening the screws (item ④) on each end until the handles are free of the analyzer.
3. Remove the four rear panel feet (item ①) by removing the center screws (item ②).
4. Slide the four bottom feet (item ③) off of the cover.
5. Slide the cover off of the frame.

Figure 2 Outer Cover Removal

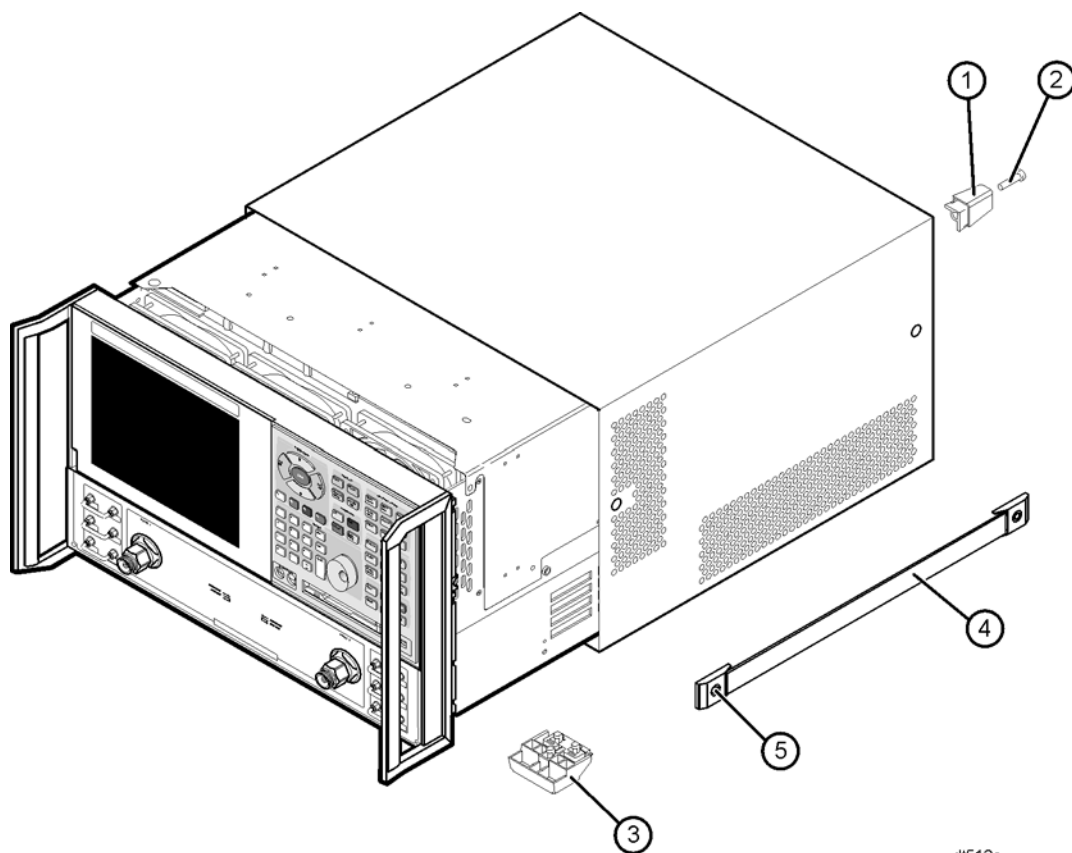

dt512a

Step 2. Raise and Remove the Receiver Swing Deck

Refer to [Figure 3](#) for this procedure.

1. Place the analyzer bottom-side up on a flat surface.
2. Remove the four screws (item ①), securing the receiver deck.
3. Pull the latch pin (item ②) toward the center of the analyzer to release the receiver deck.
4. Lift the receiver deck to partially raise it, then release the latch pin (item ②). Lift the receiver deck to its fully raised position and ensure that the latch pin latches in the raised position.
5. Disconnect all flexible cables (item ③) and ribbon cables (item ④) from the receiver swing deck. Leave these cables connected at the other end. Label the cables and connectors for proper reconnection later.
6. Pull the latch pin (item ⑤) to release one side of the receiver deck.
7. Lift the side of the receiver deck that was just released, above the side of the analyzer, and then lift the entire receiver deck out of the analyzer.

Figure 3 Receiver Swing Deck Removal

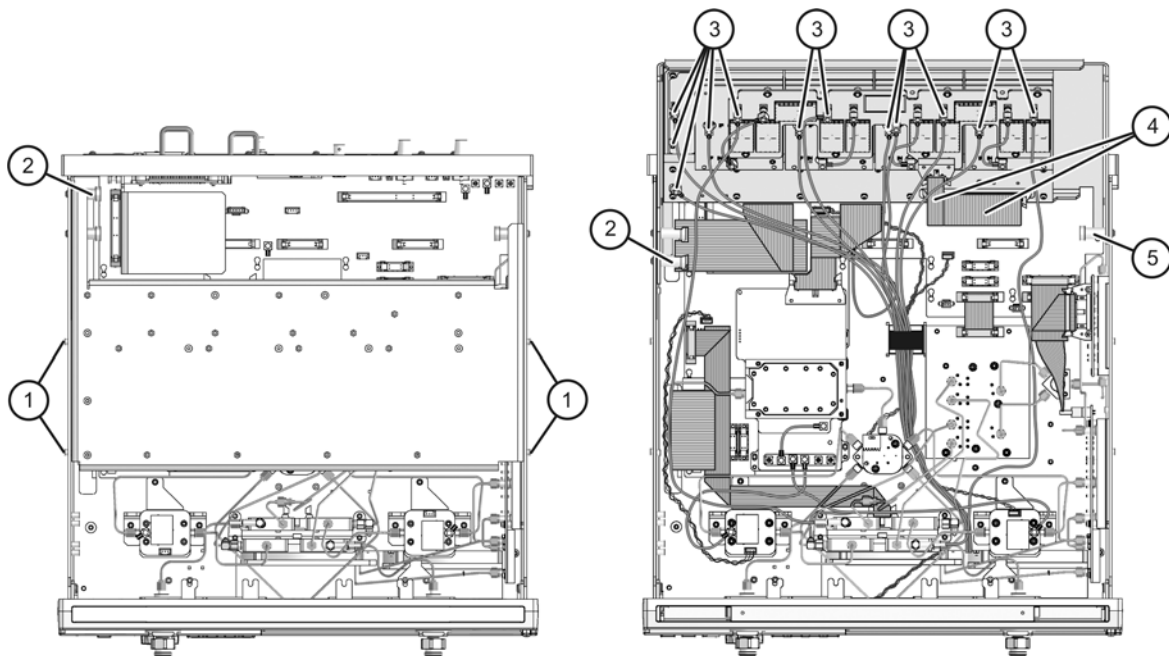

h11_01

Step 3. Remove the A41 Hard Disk Drive Assembly (HDDA) and Shield

Refer to [Figure 4](#) for this procedure.

1. Loosen the four HDDA mounting screws (item ①) on the rear panel.
2. Remove the HDDA from the analyzer by pulling on the finger grip (item ②). Moderate force may be necessary to disengage the HDDA's internal connector.

Figure 4 A41 Hard Disk Drive Assembly Removal

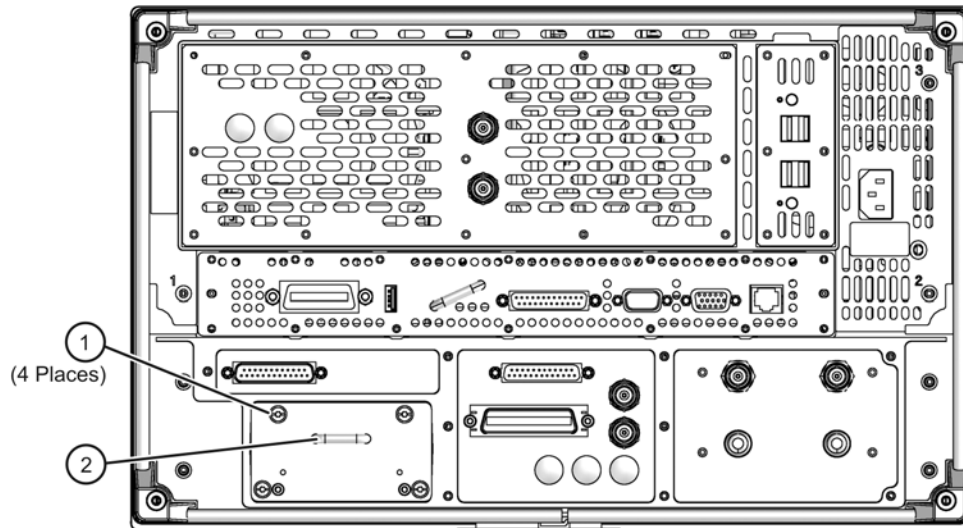

h11_08

Refer to [Figure 5](#) for this procedure.

1. Remove the HDDA shield by loosening two attachment screws (item ①). These screws are accessible through holes in the side of the chassis.
2. Remove the shield from the analyzer.

Figure 5 Hard Disk Drive Assembly Shield Removal

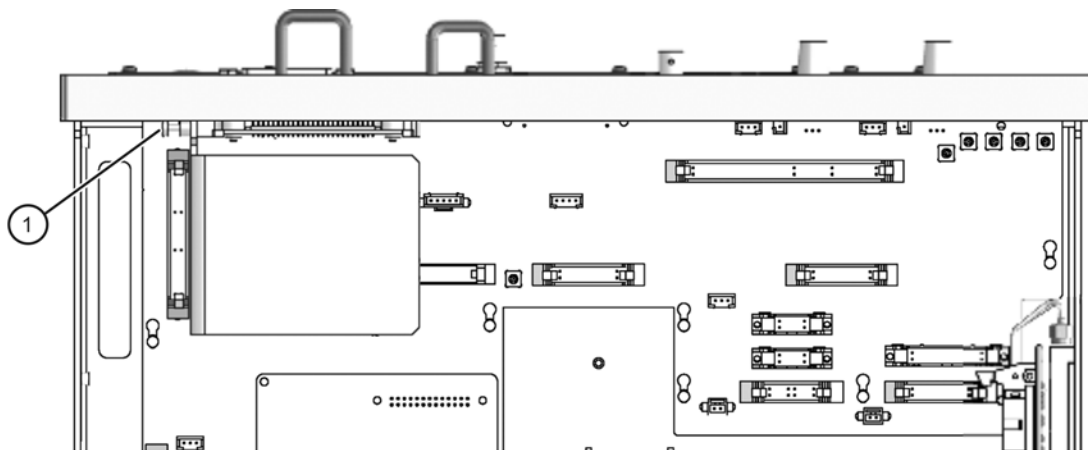

h11_03

Step 4. Remove the A21 SOMA 50 and Port 2 Assemblies

Refer to [Figure 6](#) for this procedure.

1. For the E8361A, E8363B, and E8364B, remove all cables from the A21 SOMA 50. For the E8362B, remove the cable between the A12 source and the A22 switch/splitter. Remove all cables from the port 2 source attenuator, bias tee, and either SOMA 70 (E8361A), fixed attenuator (E8362B), or detector (E8363/4B).
2. Remove the attachment screws from the SOMA 50 and from the bracket holding the port 2 source attenuator, bias tee, etc., and remove each from the analyzer.

Figure 6 A21 SOMA 50 and Port 2 Assemblies Removal

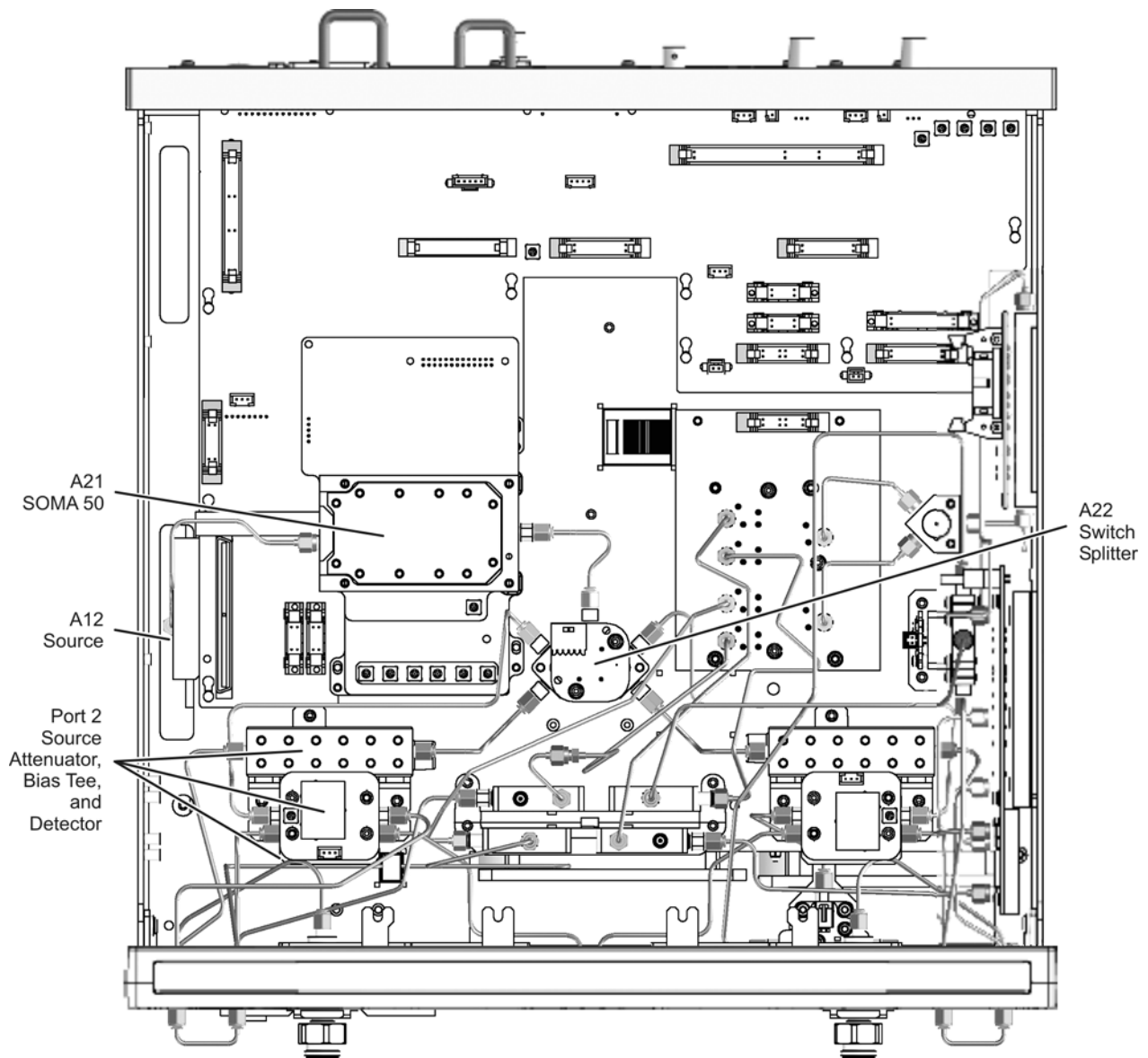

h11_02

Step 5. Remove the A18 MA 24 and the A19 Splitter

Refer to [Figure 7](#) for this procedure.

1. Remove all cables from the A18 MA24 and the A19 splitter.
2. Remove the attachment screws from the A18 MA 24 and the A19 splitter and remove each from the analyzer. Set these assemblies aside for reinstallation later.

Figure 7 A18 MA 24 and A19 Splitter Removal

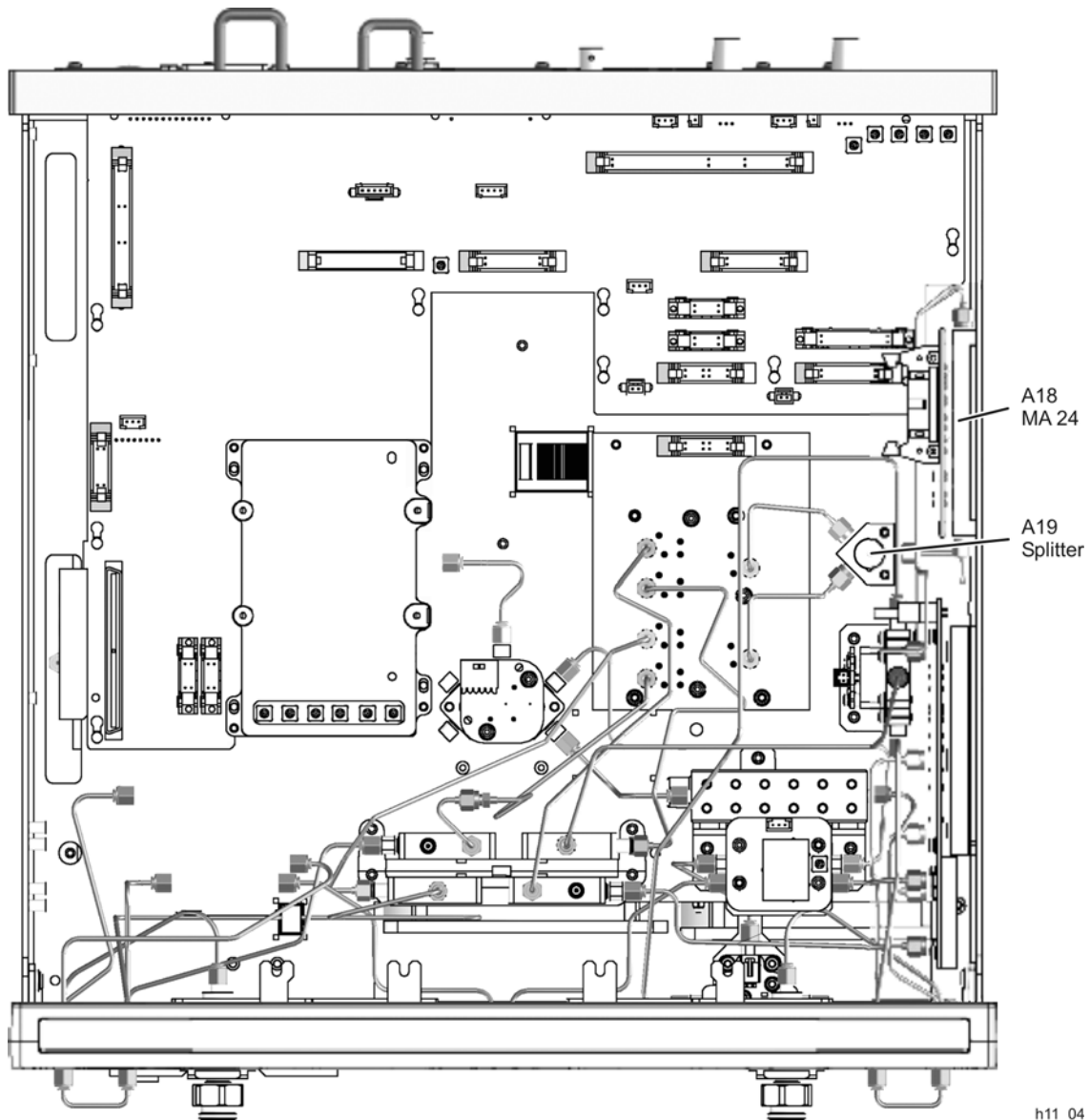

Step 6. Remove the A16 Test Set Motherboard

Refer to [Figure 8](#) for this procedure.

1. Disconnect all ribbon cables, wrapped-wire cables, and flexible cables from the A16 test set motherboard.
2. Remove nine screws (item ①) from the rear panel and four screws (item ②) from the A16 test set motherboard.
3. Slide the A16 test set motherboard toward the front of the instrument to release the locking pins (item ③), then lift the motherboard and remove it from the analyzer.

Figure 8 A16 Test Set Motherboard Removal

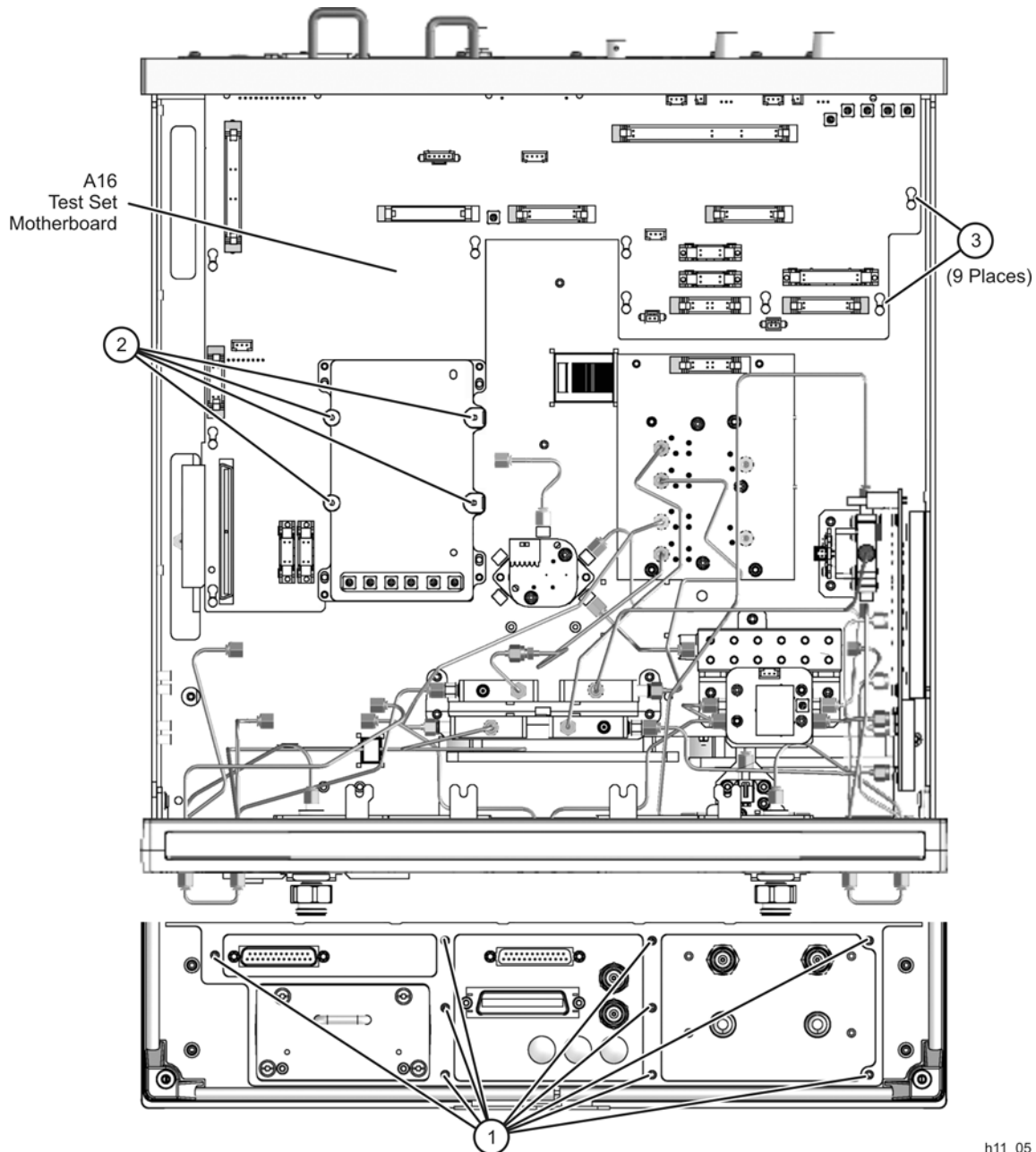

h11_05

Step 7. Replace the Rear-Panel Assembly

Refer to [Figure 9](#) for this procedure.

1. Disconnect all rear-panel cables that are attached to the A16 test set motherboard.
2. Remove the hex nuts and lock washers from the TEST SET I/O, AUX I/O and BIAS INPUT connectors and remove the rear-panel assembly from the A16 test set motherboard.
3. Remove the BIAS INPUT fuse holders, the HANDLER I/O connector, and the I/O 1 (TRIG IN) and I/O 2 (TRIG OUT) connectors from this rear panel and install them on the new rear panel provided.
4. Install the eight new cables provided in the holes labeled PULSE IN and 8.33 MHz IF IN on the new rear panel.
5. Install the two SMA f-f connectors in the two holes labeled TEST SET DRIVERS and install an SMA termination (provided) on each.
6. Place the new rear-panel assembly on the A16 test set motherboard and reinstall the lock washers and hex nuts on the TEST SET I/O, AUX I/O, and BIAS INPUT connectors.
7. Connect the appropriate cables between the new rear-panel assembly and the A16 test set motherboard. The 8.33 MHz IF IN and PULSE IN cables will be connected to the receiver swing deck later.
8. Set aside the A16 test set motherboard, with new rear-panel assembly attached, for reinstallation later.

Figure 9 A16 Test Set Motherboard Rear-Panel Assembly Replacement

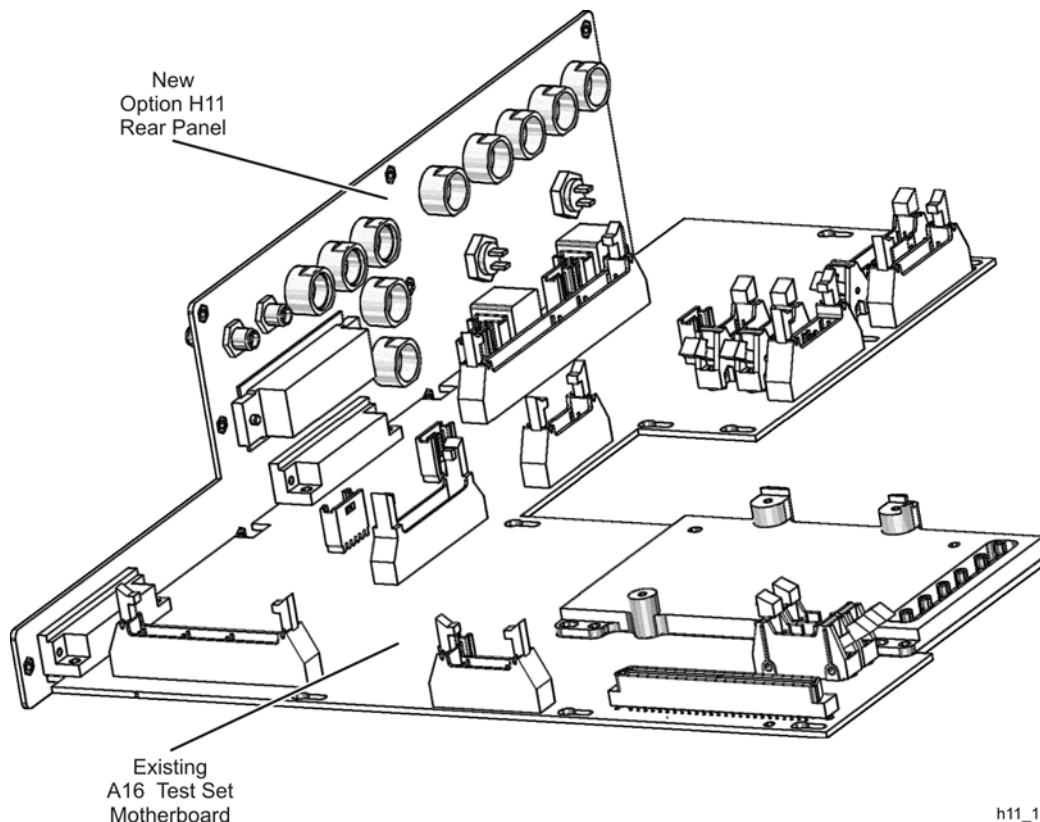

Step 8. Drill A47 RF Coupler Mounting Holes

Refer to [Figure 10](#) for this procedure.

1. Place the analyzer top-side up on a flat work surface. Be careful not to pinch any cables under the analyzer.
2. Using scissors or a sharp hobby knife, *carefully* cut out one of the templates located at the end of this installation note and place it on the analyzer side frame in the location specified in [Figure 10](#). Once the template is in the proper position, secure it with adhesive tape.
Note: An extra template is supplied in case one is damaged. Only one is required.
3. Center punch and drill two 3.2 mm (1/8-inch) holes at the locations specified. Be careful not to allow any of the metal shavings to enter the analyzer. With the analyzer positioned top-side up, the shavings should fall onto the work surface.
4. Lift the side of the analyzer just drilled and carefully remove any metal shavings from the analyzer and from the work surface. Especially make sure that the newly drilled holes are clear of any metal shavings.
5. Place the analyzer back into the bottom-side up position on the work surface.

Figure 10 Drilling A47 RF Coupler Mounting Holes

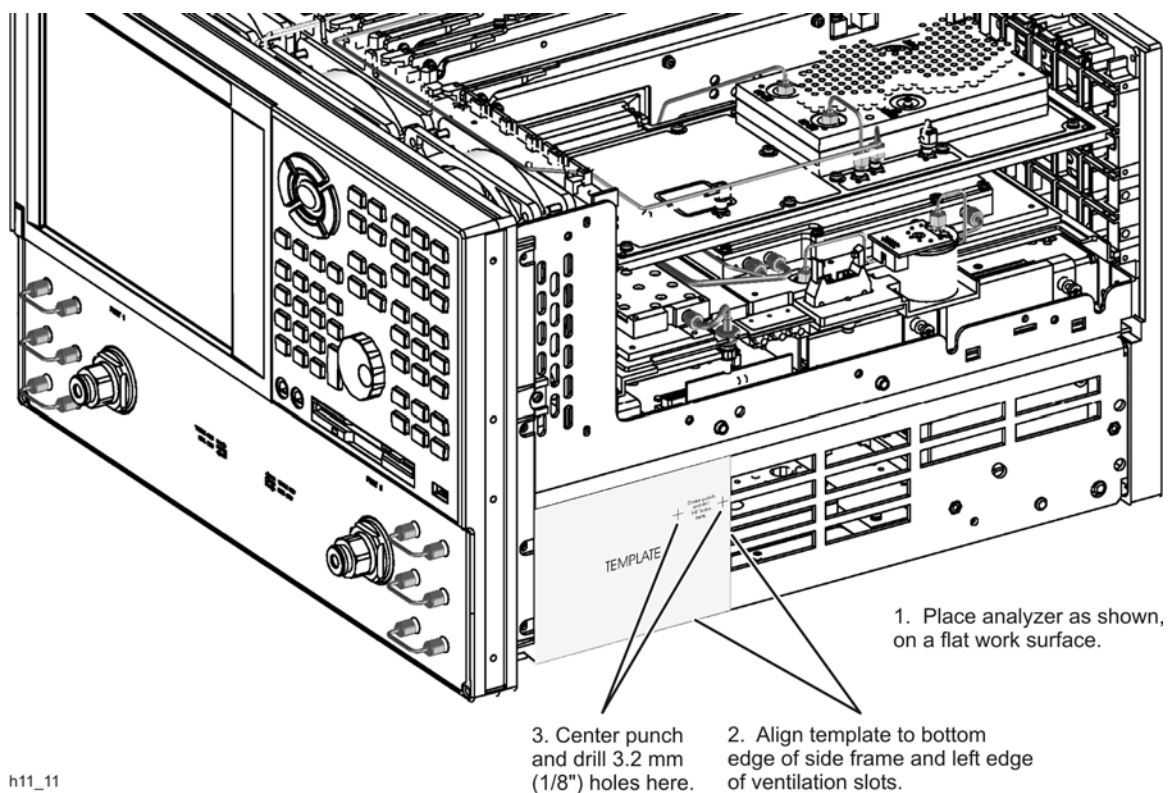

Step 9. Install the New A16 Test Set Motherboard

Refer to [Figure 11](#) for this procedure.

1. Align the A16 test set motherboard with all of the locking pins (item ③) and then slide the board towards the rear of the analyzer to lock the pins.
2. Reinstall nine screws (item ①) in the rear panel and four screws (item ②) in the A16 test set motherboard
3. Reconnect all ribbon cables, wrapped-wire cables, and flexible cables to the A16 test set motherboard.

Figure 11 A16 Test Set Motherboard Installation

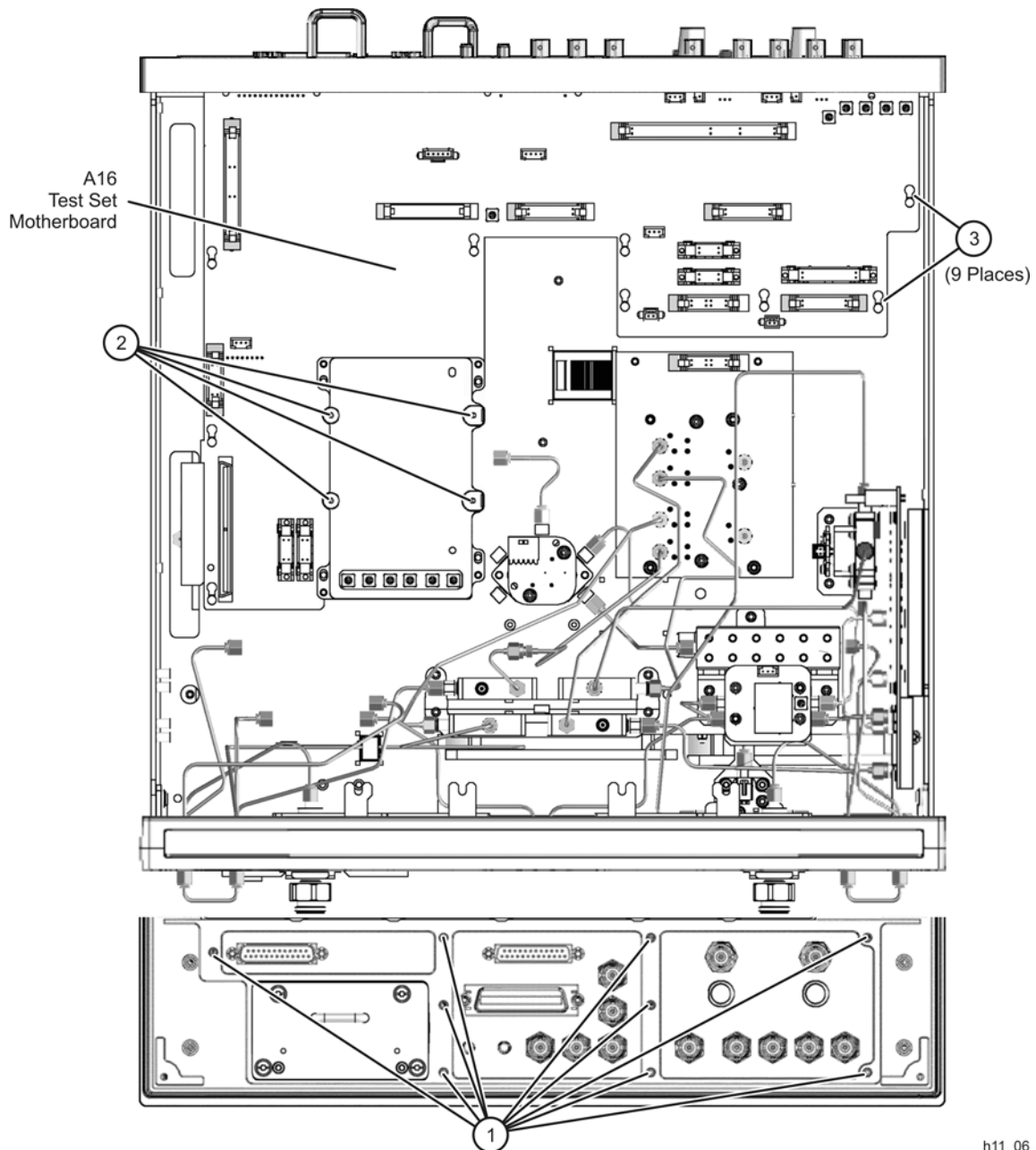

h11_06

Step 10. Reinstall the A41 Hard Disk Drive Assembly (HDDA) and Shield

Refer to [Figure 12](#) for this procedure.

1. Place the HDDA in the analyzer as shown and push. Moderate force may be necessary to engage the HDDA's internal connector.
2. Tighten the four mounting screws (item ①) on the rear panel.

Figure 12 A41 Hard Disk Drive Assembly (HDDA) Reinstallation

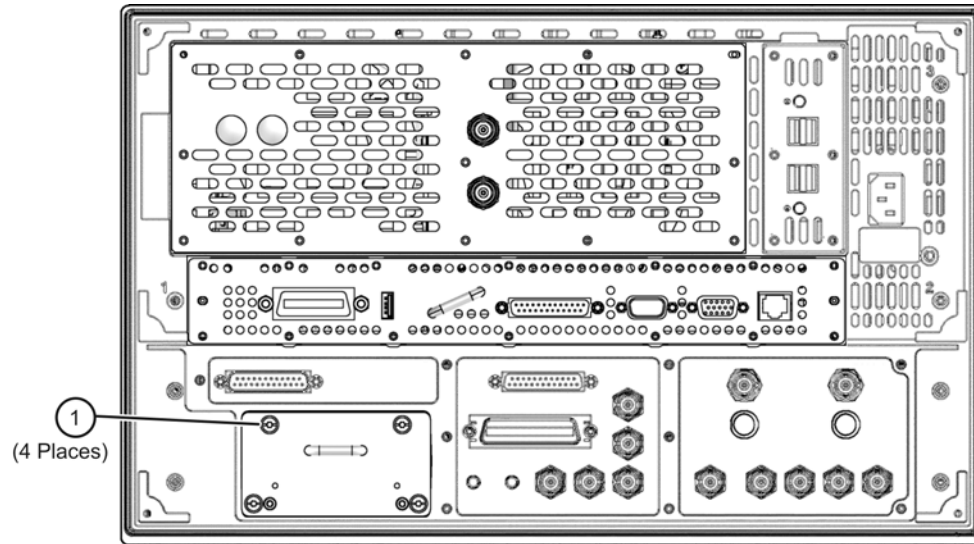

h11_07

Refer to [Figure 13](#) for this procedure.

1. Place the HDDA shield in position in the analyzer.
2. Secure the shield by tightening two attachment screws (item ①). These screws are accessible through holes in the side of the chassis.

Figure 13 Hard Disk Drive Assembly Shield Reinstallation

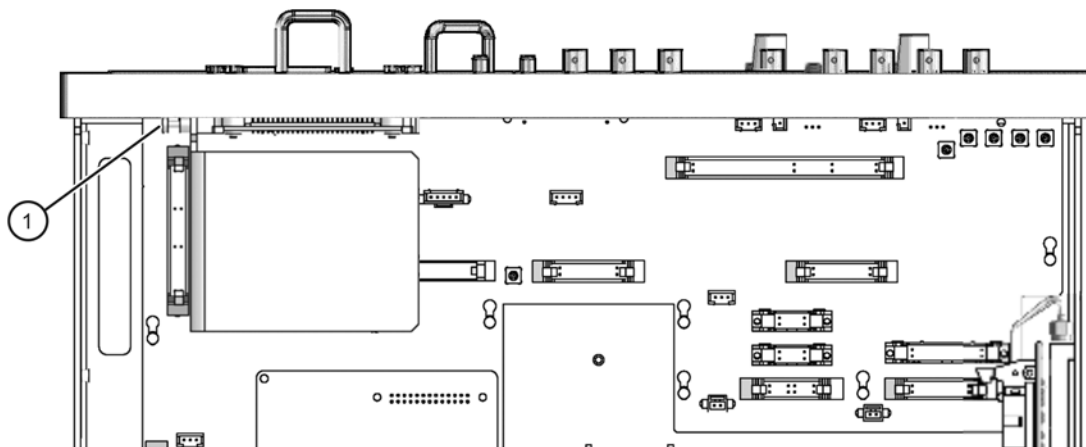

h11_16

Step 11. Reinstall the A21 SOMA 50 and the Port 2 Assemblies

Refer to [Figure 14](#) for this procedure.

1. Place the bracket holding the port 2 source attenuator, bias tee, etc., in the analyzer and reinstall the attachment screws.
2. Place the A21 SOMA 50 in the analyzer and reinstall the attachment screws.
3. Reinstall all cables to the port 2 source attenuator, bias tee, and either SOMA 70 (E8361A), fixed attenuator (E8362B), or detector (E8363/4B).
4. Reinstall the cable between the A21 SOMA 50 and the A22 switch/splitter. Do not reinstall the cable between the A12 source and the A21 SOMA 50 (or between the A12 source and the A22 switch/splitter for the E8362B). This is where the A47 RF coupler will be inserted.

Figure 14 A21 SOMA 50 and Port 2 Assemblies Reinstallation

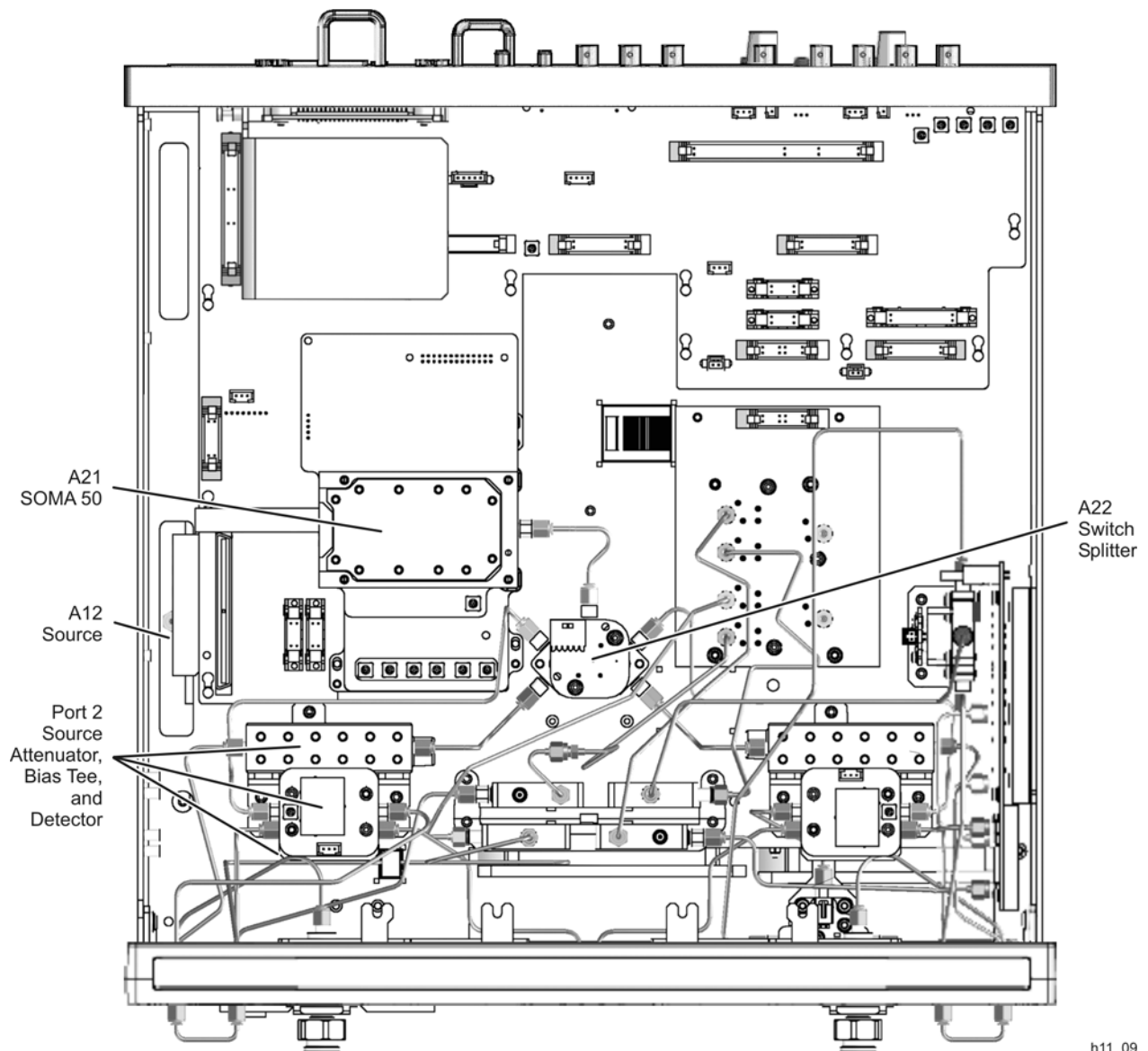

Step 12. Install the A47 RF Coupler

Refer to [Figure 15](#) for this procedure.

1. Place the A47 RF coupler in the analyzer, aligning it with the new holes drilled in the side frame, and *loosely* install the two screws provided.
2. Install the new cables from the A12 source to the A47 RF coupler, from the A47 RF coupler to the A21 SOMA 50, and from the A47 RF coupler to the rear panel TEST SET DRIVERS RF connector.
3. Go back and tighten the A47 RF coupler attachment screws.

Figure 15 A47 RF Coupler Installation

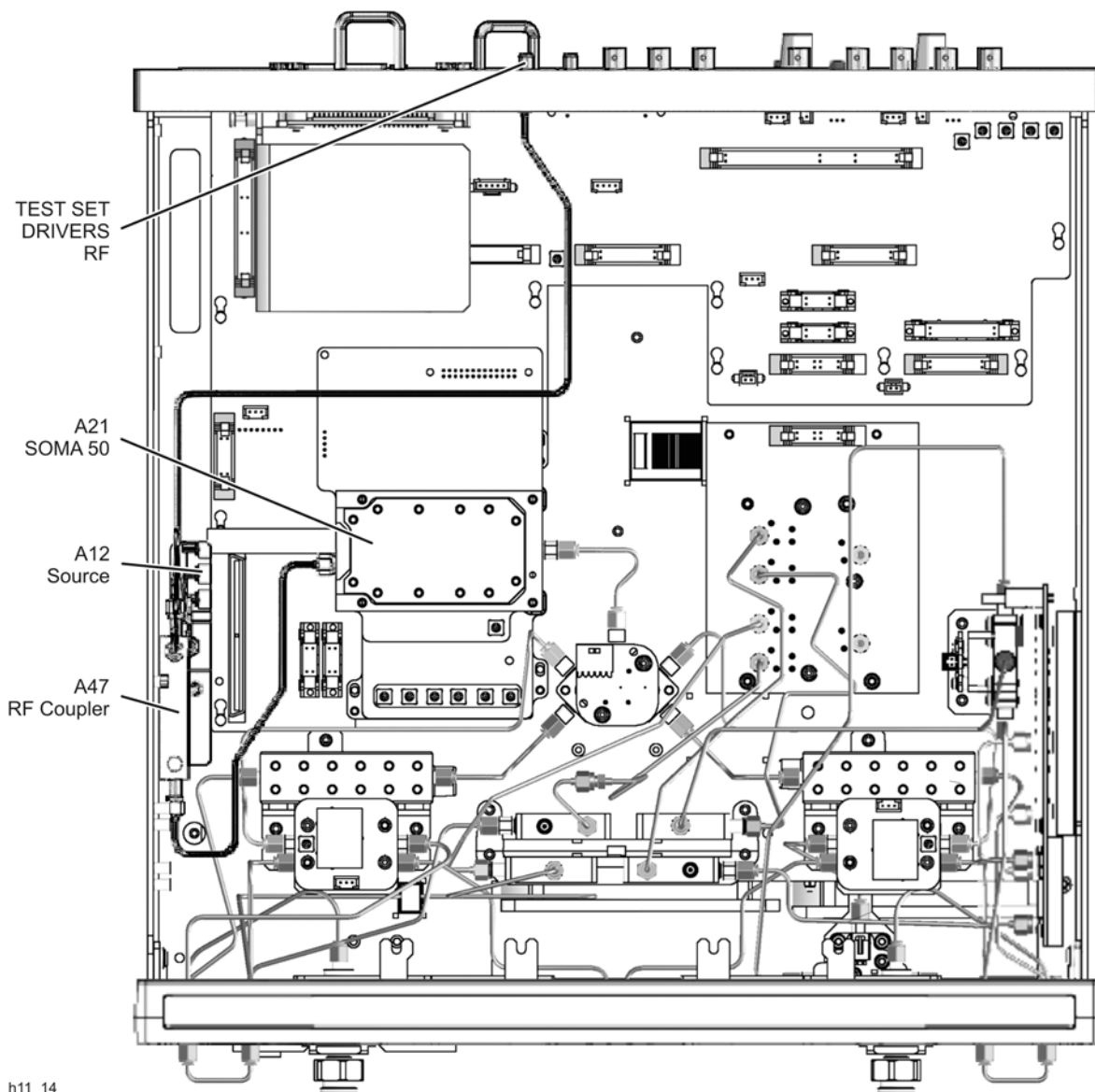

Step 13. Replace Switch Cable (E8361A Only)

Remove the Front Panel Assembly (E8361A Only)

Refer to [Figure 16](#) for this procedure.

1. With a 5/16-inch wrench, remove the six front panel semirigid jumper cables (item ①).
2. With a T-10 TORX driver, remove the eight screws (item ②) from the sides of the frame.

CAUTION Before removing the front panel from the analyzer, lift and support the front of the analyzer chassis.

3. Slide the front panel over the test port connectors.
4. Disconnect the front panel interface ribbon cable (item ③) from the A3 front panel interface board. The front panel is now free from the analyzer.

Figure 16 Front Panel Assembly Removal and Reinstallation (E8361A Only)

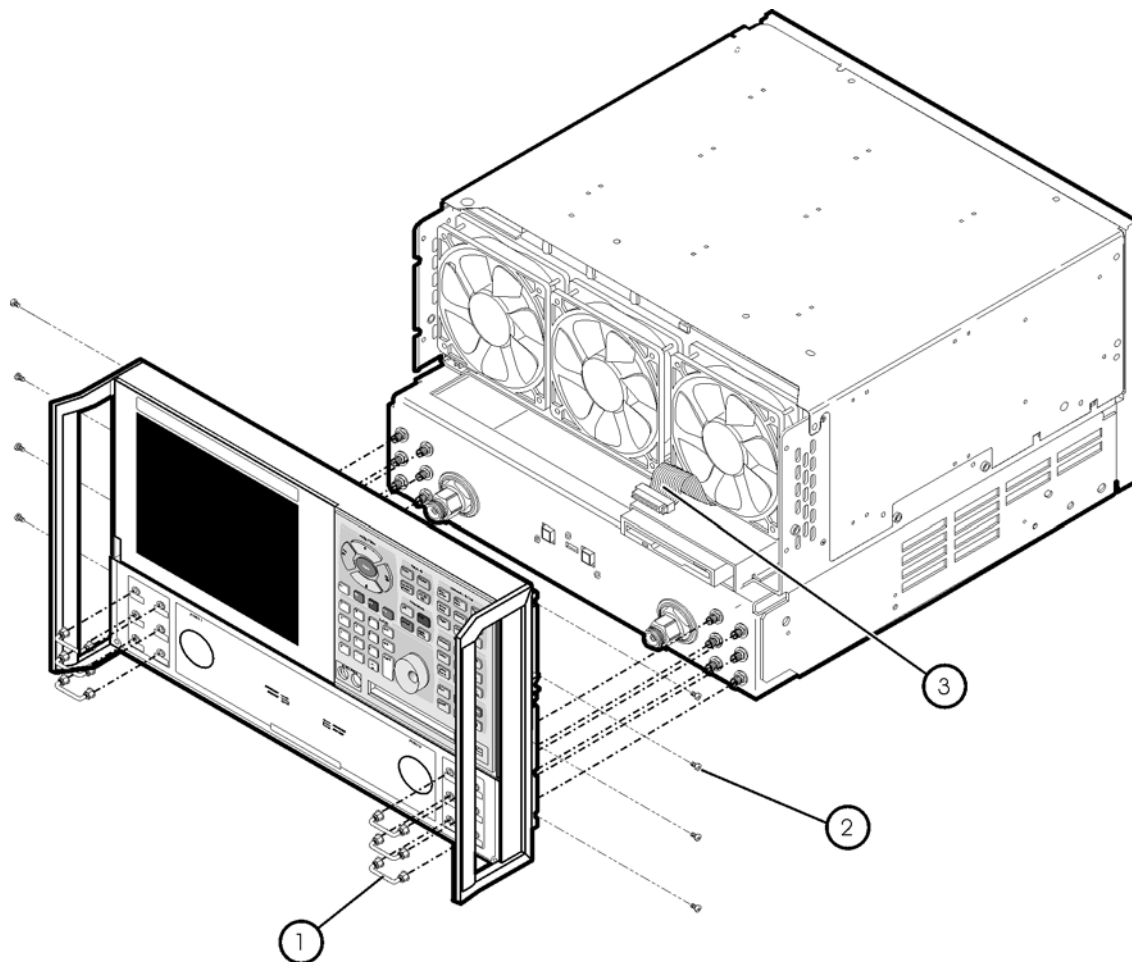

st536a

Replace the Switch Cable (E8361A Only)

Refer to [Figure 17](#) for this procedure.

1. Replace cable W98 with the new cable provided. It will be necessary to remove the nut and washer from the front panel connector. Use these to install the new cable. Be sure to torque the front panel cable nut to 21 in-lbs when installing the new cable.

Figure 17 Switch Cable Replacement (E8361A Only)

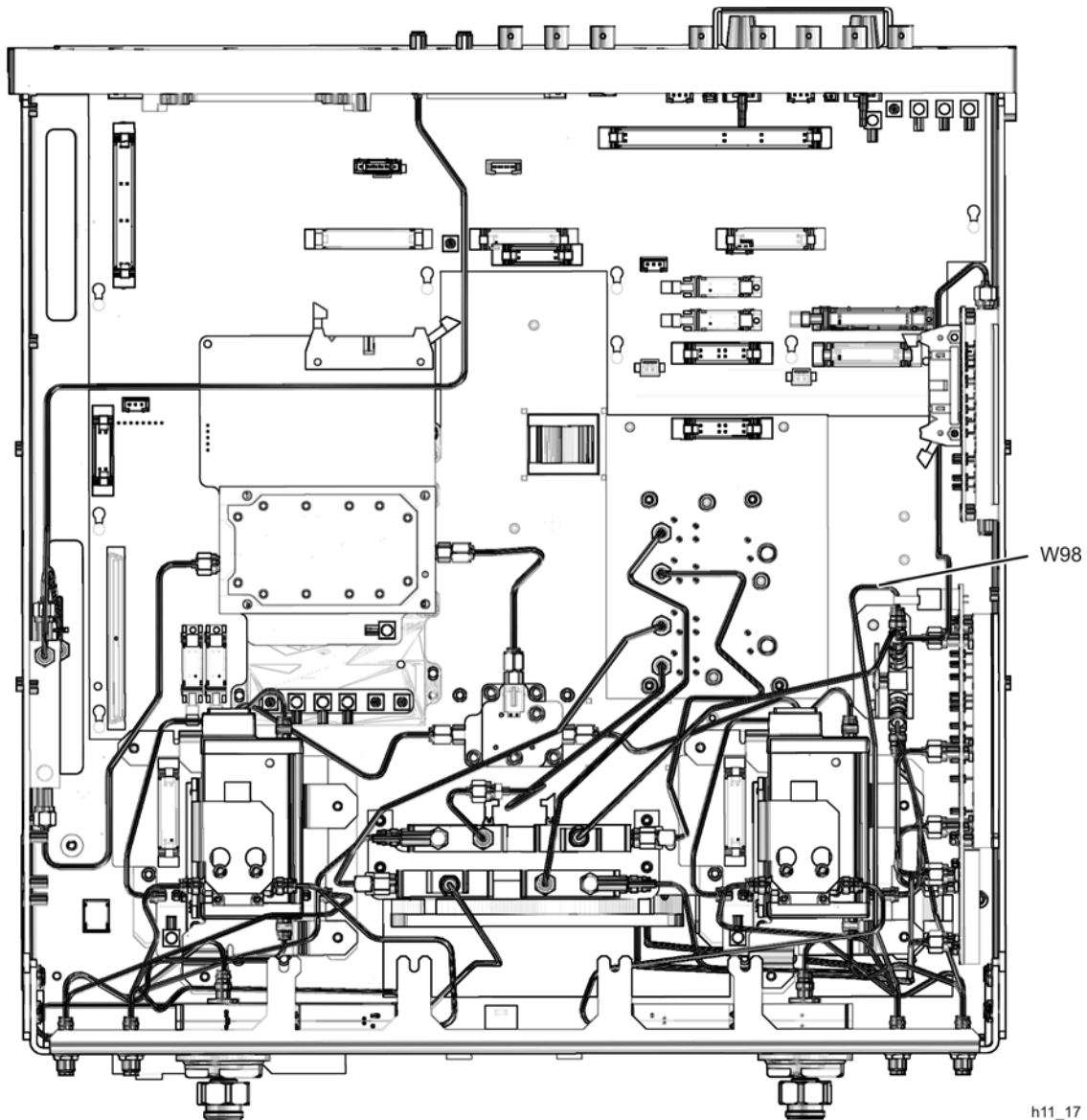

h11_17

Reinstall the Front Panel Assembly (E8361A Only)

Refer to [Figure 16](#) for this procedure.

1. Reinstall the front panel assembly by reversing the instructions under [“Remove the Front Panel Assembly \(E8361A Only\)”](#) on page 20.

Step 14. Install the A18 MA 24, A19 Splitter, and A48 LO Coupler

Refer to [Figure 18](#) for this procedure.

1. Place the A18 MA 24 in the analyzer and reinstall the attachment screws.
2. Install the A19 splitter and the A48 LO coupler onto the new splitter bracket provided. Install the new cable provided between the A48 LO coupler and the A19 splitter.
3. Place the splitter bracket, with the A19 splitter and A48 LO coupler attached, in the analyzer and install the attachment screws.
4. Connect the new cable provided from the A18 MA 24 to the A48 LO coupler.
5. Install the new cable provided from the A48 LO coupler to the rear panel TEST SET DRIVERS LO connector.
6. Reconnect the other cables to the A18 MA24 and the A19 splitter. Note that, since the A19 splitter is now in a different location, there are new cables provided to replace the old ones.

Figure 18 A48 LO Coupler Installation

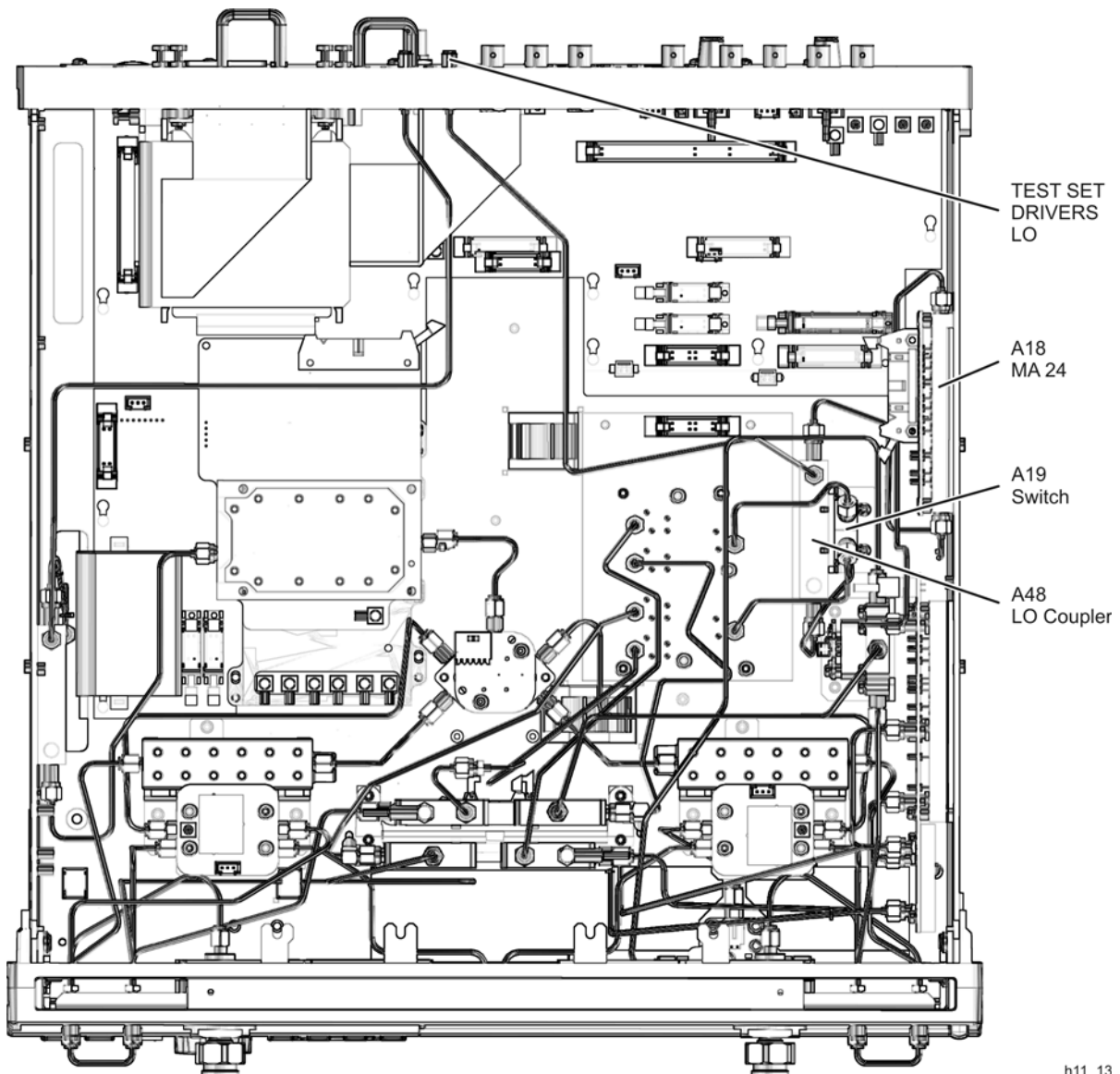

h11_13

Step 15. Install the A49 IF Multiplexer Board

Refer to [Figure 19](#) for this procedure.

NOTE Your analyzer may already have this board installed. Check the part number on the board to determine if it needs to be changed. If the part number is E8361-20043, or if the board looks like that shown in [Figure 19](#), it is the new A49 IF multiplexer board and does not need to be changed; proceed to the next step in this procedure.

1. Disconnect four flexible cables (item ①) from the switch/LO reject filter board. Leave the other ends of these cables attached to the receivers.
2. Remove the switch/LO reject filter board by removing eight attachment screws (item ②).
3. Install the new A49 IF multiplexer board in place of the old switch/LO reject filter board using the eight screws (item ②) removed from the old board.
4. Connect the four flexible cables (item ①), that were previously disconnected, to the new A49 IF multiplexer board.

Figure 19 A49 IF Multiplexer Board Installation

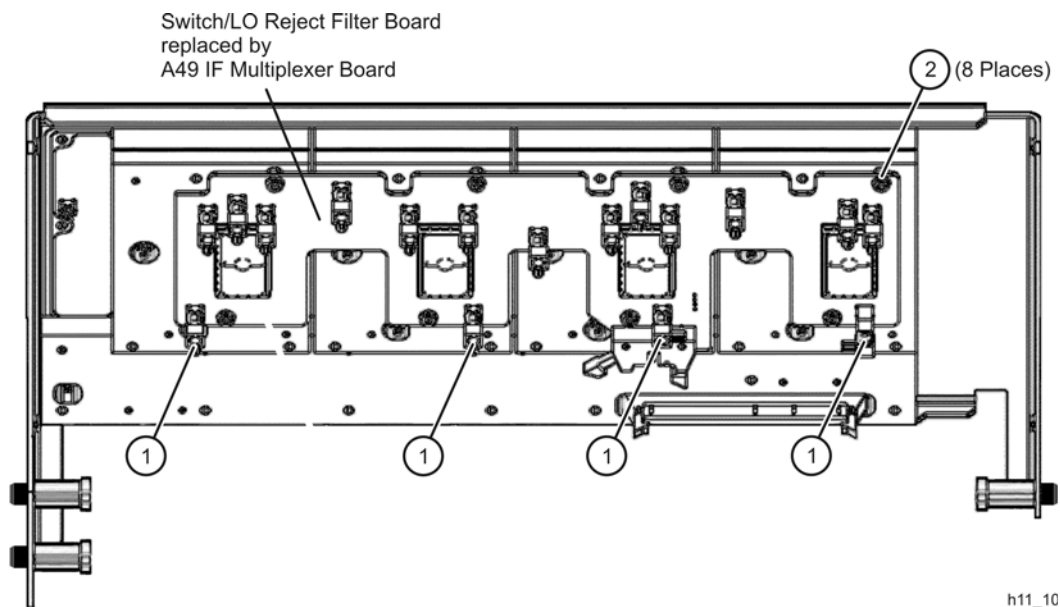

Step 16. Reinstall the Receiver Swing Deck and Associated Cables

Refer to [Figure 20](#) for this procedure.

1. Place the receiver swing deck in the analyzer by tilting it so that the hinge pin and the latch pin (item ①) can be inserted in the appropriate holes in the side frame, with the receiver swing deck in the raised position.
2. Pull the latch on the other hinge pin, to compress the spring, and lower the receiver deck into the analyzer and align the other hinge pin (item ②) with the appropriate hole in the side frame. Leave the receiver deck in the raised position.
3. Reconnect the flexible cables (item ③), that were previously disconnected, to the receiver deck.
4. Connect the 8.33 MHz IF IN cables (item ④) and the PULSE IN cables (item ⑤) to the receiver deck. Receivers A, R1, R2, and B are labeled in [Figure 20](#).
5. Reconnect the ribbon cables (item ⑥) to the receiver deck.
6. Pull the latch pin (item ①) toward the center of the analyzer to release the receiver deck.
7. Lift the receiver deck to partially lower it, then release the latch pin (item ①). Lower the receiver deck to its fully lowered position and ensure that the latch pin latches in the lowered position.
8. Reinstall the four attachment screws (item ⑦) in the receiver deck.

Figure 20 Receiver Swing Deck Reinstallation

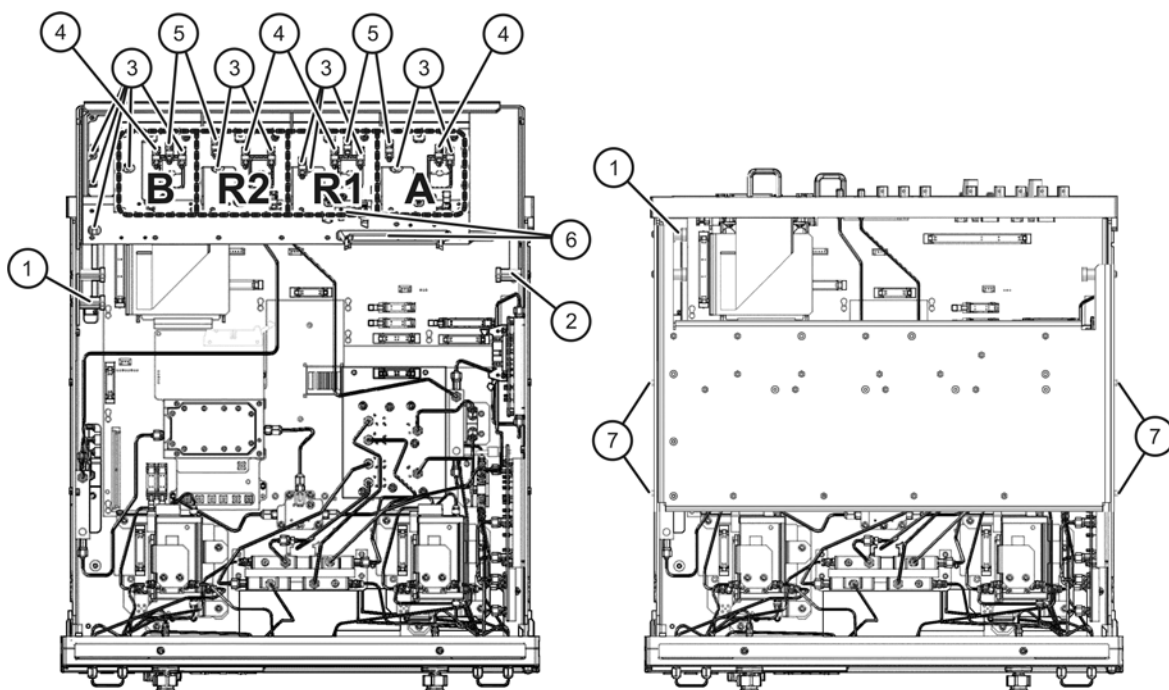

h11_15

Step 17. Reinstall the Outer Cover

Refer to [Figure 21](#) for this procedure.

CAUTION This procedure is best performed with the analyzer resting on its front handles in the vertical position. *Do not place the analyzer on its front panel without the handles.* This will damage the front panel assemblies.

1. Slide the cover over the analyzer frame.
2. Install the four rear panel feet (item ①) by installing the center screws (item ②).
3. Slide the four bottom feet (item ③) onto the cover.
4. Install the strap handles (item ⑤) by tightening the screws (item ④) on each end of the handles.

Figure 21 Outer Cover Reinstallation

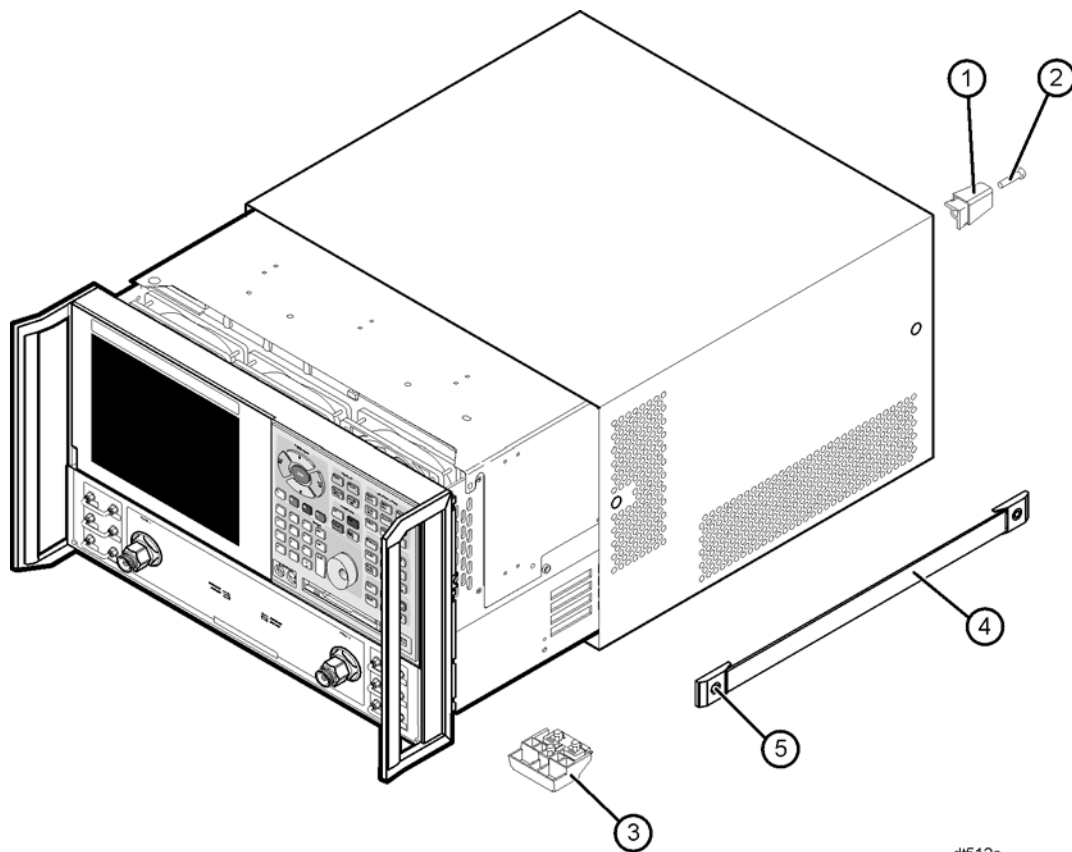

dt512a

Step 18. Enable Option H11

Procedure Requirements

- The analyzer must be powered up and operating to perform this procedure.
- The Network Analyzer program must be running.
- A mouse must be connected to the analyzer for this procedure.

Option Enable Procedure

1. On the analyzer's **System** menu, point to **Service**, and then click **Option Enable**.
2. In the **Select Desired Option** list, click **H11 - IF Access**.
3. Click **Enable**.
4. Click **Yes** in answer to the displayed question in the **Restart Analyzer?** box.
5. When the installation is complete, click **Exit**.

Option Verification Procedure

1. On the analyzer's **Help** menu, click **About Network Analyzer**.
2. Verify that "H11" is listed after "Options:" in the display. Click **OK**.

NOTE

If Option H11 has not been enabled, perform the "[Option Enable Procedure](#)" again. If the option is still not enabled, contact Agilent Technologies. Refer to "[Getting Assistance from Agilent](#)" on page 28.

Step 19. Verify the Functionality of Option H11

To verify that the Option H11, IF Access, upgrade is functioning properly:

1. Download and install the latest PNA firmware from the PNA Service & Support Home Page at: <http://na.tm.agilent.com/pna/firmware/firmware.htm>.
2. On the PNA, select **System**, then **Service**, then **H11 Verify**.
3. Follow the program prompts. Help is available on the Help tab.

Getting Assistance from Agilent

By internet, phone, or fax, get assistance with all your test and measurement needs.

Contacting Agilent

Assistance with test and measurements needs and information on finding a local Agilent office are available on the Web at:

<http://www.agilent.com/find/assist>

If you do not have access to the Internet, please contact your Agilent field engineer.

NOTE In any correspondence or telephone conversation, refer to the Agilent product by its model number and full serial number. With this information, the Agilent representative can determine whether your product is still within its warranty period.

Templates for Drilling RF Coupler Mounting Holes

